

Installation & Assembly Instructions



This symbol on the product means the product is listed by Underwriters Laboratories, Inc.

ROUND AMERI-VENT® TYPE B GAS VENT

Model 'E' - Sizes 3" through 6"

Model 'R' - Sizes 7" through 30"

OVAL AMERI-VENT® GAS VENT - Model 'O'

Size 4" - Type B, Type B 2x4, Type BW

Size 5" - Type B, Type B 2x4

Size 6" - Type B

AMERI-VENT GAS VENT AND ACCESSORIES ARE FOR USE ONLY WITH LISTED GAS FIRED APPLIANCES EQUIPPED WITH A DRAFT HOOD OR OTHER APPLIANCES LISTED FOR USE WITH TYPE B GAS VENT.

AMERI-VENT GAS VENT AND ACCESSORIES ARE NOT TO BE USED WITH INCINERATORS OR WITH APPLIANCES BURNING SOLID OR LIQUID FUELS.*

Vent sizing and installation are to be made in accordance with all applicable local building codes. For further information, please consult the National Fuel Gas Code (NFPA 54).

USAGE

Ameri-Vent Gas Vent and fittings are intended to form a continuous passageway from the gas appliance to the termination of the vent above the roof, including the vent cap.

*For fuels other than gas, write for Ameri-Tec or VSI Chimney Information.



American Metal Products

General Installation Guidelines

1. Adequate air supply must be provided for combustion and venting of appliance. Local codes or NFPA 54 specify minimum requirements for combustion ventilation and dilution air.

NOTE: Failure to provide adequate air may result in extreme hazards to life.

2. Ameri-Vent Gas Vent is suitable for installation inside or outside. However, the sizing tables in NFPA 54 are for vents not exposed to the outdoors below the roof line. Outside vents could reduce venting action; therefore, such installations are not recommended. In the event outside venting is necessary, vents should be sized as close to maximum capacity as possible. Whenever possible outside vents should be enclosed inside a chase which maintains the minimum one (1) inch clearance to combustibles. Appliances served by an outside vent must have an adequate air supply to balance inside and outside air pressure to reduce the possibility of reverse venting action.

3. The vent should be sized for the sea level name plate input rating of the appliance in accordance with the procedures set forth in NFPA 54 (The National Fuel Gas Code), or the American Metal Products Gas Vent Capacity Tables (EP-GVC).

4. When installing, make sure arrow on the Ameri-Vent part is pointed up or away from the appliance.

5. When installed as a Type B Gas Vent, a minimum of one (1) inch air space clearance to combustible material is required. For Type B 2x4 and BW Vents see Section 2, page 9 for clearance to combustibles. All locking joints are to be securely snap-locked together. See the rear page of these instructions for detailed information about locking and unlocking vent sections. The first vent section must be screwed to the appliance outlet collar.

6. Ameri-Flex Model FC Gas Vent Connector should be installed in accordance with our installation instructions. Unlisted single wall connector pipe shall be securely supported and joints fastened with sheet metal screws, rivets or other approved means. At the point of connection of the single wall connector pipe to the double wall gas vent, three sheet metal screws or rivets may be used as an approved means.

NOTE: Do not use sheet metal screws at the lock joints of Ameri-Vent Model E, R, and O Gas Vents

7. Wherever possible, install vertical vents directly above appliances before beginning any lateral runs. Lateral venting should be kept to a minimum to avoid vent resistance. Horizontal runs to vents should either be in accordance with the appropriate tables in NFPA 54, or should not exceed 75% of the vertical height of the vent. Laterals should be supported. Excessive

number of fittings, such as elbows and tees, should be avoided.

8. Maintain a pitch or rise from the appliance to the vent cap on horizontal runs. The pitch shall not be less than 1/4 inch to the foot.

9. Vents must terminate vertically above the roof line. Refer to the Termination of Vent Structure section on page 10 for details.

10. Strap or support vents securely in position to maintain a minimum of one (1) inch air space clearance to combustibles.

11. Firestops must be used where vents pass through floors or ceilings.

12. More than one gas appliance may be vented into a common vent. Close attention should be paid to vent sizing to assure adequate venting action.

13. Portions of gas vents which may extend through accessible spaces are to be enclosed to:

a) Maintain the one (1) inch minimum air space clearance.

b) Avoid personal contact with the vent.

c) Avoid damage to the vent.

IMPORTANT: The enclosure must provide a minimum of one (1) inch air space to all combustible material and building insulation. Refer to section 2, page 9 for Type B 2x4 and BW clearances.

14. In many types of buildings, such as multi-family residential, high-rise and others, vents which pass through floors or ceilings must be located in fire rated shafts or chases with no openings, except for inspection access. Consult local building code for proper wall construction, access, clearance, support, initial penetration of breaching and method of termination, or refer to the National Fuel Gas Code (NFPA 54).

15. Never vent gas appliances into an unlined masonry chimney. Install either Type B Gas Vent or a listed metal relining system inside chimney to reduce condensation and reduce the chances of improper venting which could occur in unlined chimneys.

NOTE: While handling sheet metal parts, it is advisable to wear gloves to avoid personal injury from sharp edges or projections.

16. If a power vent fan is used, make sure it is located at the terminus so as to maintain negative pressure within the vent.

17. The gas venting system should be inspected prior to the heating season by a qualified technician. This inspection should include removal of the cap to confirm an unrestricted vent.

Installation

Beginning Vent Structure with the Connector or Breeching System

Singlewall Connectors

Connect the Singlewall to the draft hood of the appliance with three (3) sheet metal screws. Each joint of the singlewall system must be connected with three (3) sheet metal screws. Singlewall connector **must not** penetrate any walls or ceilings, or be used in any cold or non routinely inspected areas. Singlewall connector pipe may extend to the first point of penetration of structure where the use of a firestop and support assembly are required. If using Ameri-Flex Connector System, refer to Ameri-Flex Model FC Installation Instructions.

Type B Gas Vent Connectors

Attach the vent section directly to the draft hood of the appliance with three (3) sheet metal screws. Allow a minimum of one (1) inch air space clearance to combustibles. Where the vent penetrates structure use the Support Plate to maintain proper clearance at this and successive intervals throughout the structure.

Section 1 Models E & R Round

Basic Vent Structure

Ameri-Vent Type B Gas Vent sizes are specified by the inside pipe diameter. Model E is available in sizes 3" through 6" diameters and has a 1/4" air space between pipe walls. Model R is available in sizes 7" through 30" diameters and has a 1/2" air space between pipe walls. When calculating the assembled length, allow 1" length reduction for the overlap at each joint.

Support of Vent Structure

American Metal Products offers three different types of supports as explained below. In addition, field-fabricated supports may be used. Consult local building codes for applicable regulations regarding field-fabricated supports.

Directions for Installing Ameri-Buckets

NOTE: Ameri-Bucket Hangers (ABH) are available for sizes 3 inch through 8 inch only. Hangers are designed to

fit between 16 inch on-center joists. Ameri-Buckets in size 9 inch and larger do not use hangers. Instead, they must be nailed in place into a properly sized, framed-in opening. Ameri-Buckets in sizes 3 inch through 8 inch may also be nailed in place into a properly sized, framed-in opening as an alternative to using bucket hangers.

Installations Using Ameri-Buckets (AB) with Hangers (ABH) (Sizes 3 inch through 8 inch only)

1. Check to see that center-to-center distance between joists is 16 inches nominal.
2. Bend the four rectangular tabs inward on Ameri-Bucket. This will center vent pipe and maintain 1 inch minimum clearance to outside wall of Ameri-Bucket. See **Fig. 1**.

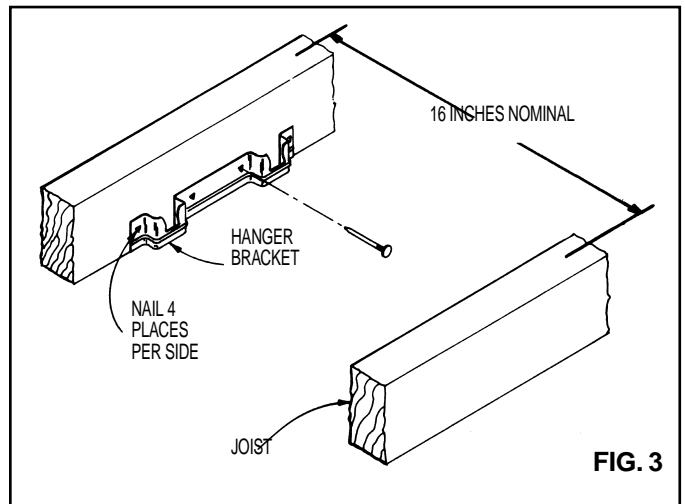
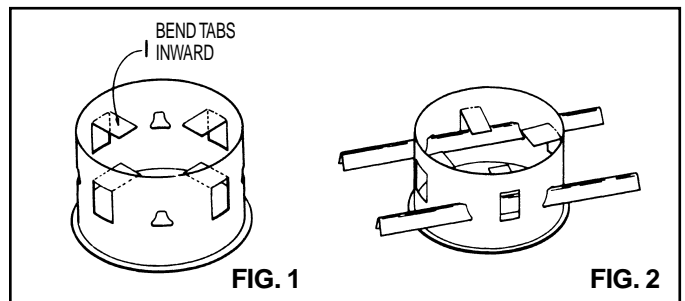

3. Place U-shaped hanger bars through pairs of openings in the side of the Ameri-Bucket. Note that open portion or U-shaped bar faces downward. Do not use rectangular openings with inward-bent tabs. Instead, pass hanger bars through closest pairs of plain openings as shown in **Fig. 2**.
4. Nail both hanger brackets into sides of joists. Bottom edge of brackets should be even with bottom edge of joists. Use four nails per bracket, nailing through small triangular-shaped openings in brackets. **DO NOT RELY ON TRIANGULAR-SHAPED BARBS TO HOLD BRACKETS IN PLACE. BRACKETS MUST BE NAILED TO JOISTS.** See **Fig. 3**.
5. Snap hanger bars into slots in hanger bracket.

Installation Using Ameri-Bucket Without Hangers

1. Completely frame in (on all four sides) a properly-sized square opening. Select opening size so that outside wall of Ameri-Bucket will contact framing at four sides. See Fig. 4.

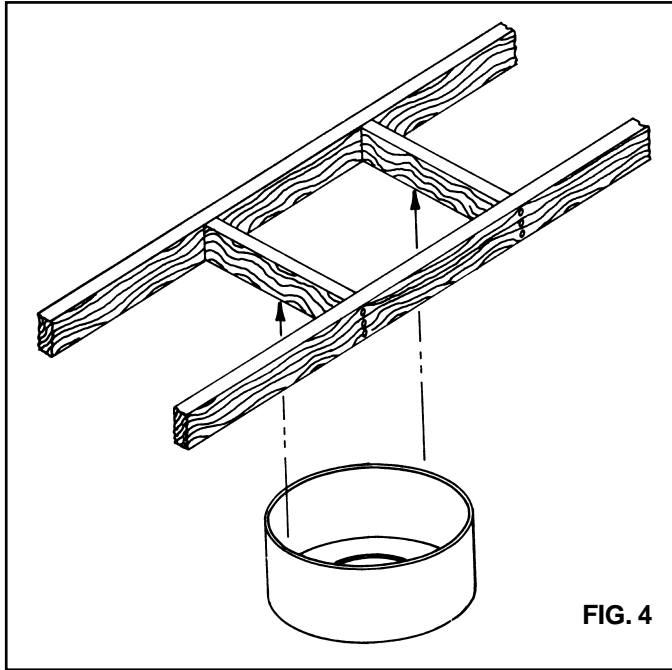

FIG. 4

2. Position Ameri-Bucket through opening so that bottom of Bucket will be flush with, or a little below, bottom of ceiling.

3. Nail through sides of Ameri-Bucket into framed-in opening. Nail on all four sides, using a minimum of two nails per side (8 nails total, minimum).

Bucket Connectors

The Bucket Connector (BC) is used to make the connection of either Ameri-Flex single wall connector pipe, or Ameri-Vent Type B Gas Vent, utilized as connector, through the bottom of the Ameri-Bucket.

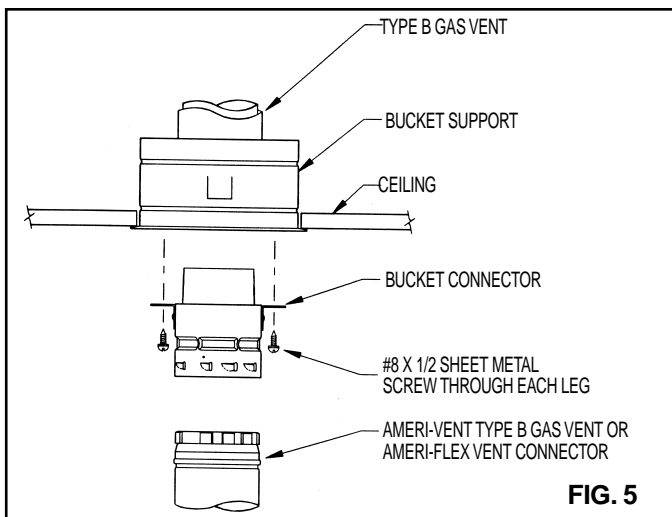

FIG. 5

1. The Bucket Connector is installed by positioning it against the bottom of the Ameri-Bucket, as shown in Fig. 5 with the mounting tabs against the bottom of the bucket.

2. Position the inner wall of the Bucket Connector inside the bottom end of the inner wall of the B Vent section through the hole in the bottom of the bucket. Attach the mounting tabs with sheet metal screws.

3. Provide additional strapping or hangers for connector offsets.

Firestop Supports

The Firestop Support (FSP) and Support Bracket (SB) are designed for use with Type B Gas Vent in sizes 3 inch diameter through 8 inch diameter.

When used by itself, the Firestop Support (FSP) serves as a firestop, while maintaining one inch clearance to combustibles from the outer wall of the Type B Gas Vent. When the Firestop Support (FSP) is used with the Support Bracket (SB), this combination of parts serves as both a firestop as well as a support. Each support is designed to support up to 20 feet of vent pipe when installed as follows:

1. It is recommended that the Vent Pipe be supported at least every other floor. The distance between supports must not, in any case, exceed 20 feet.

2. Frame in an opening providing one inch clearance to Ameri-Vent Type B Gas Vent. See Fig. 6, Table 1.

Table 1	
VENT SIZE	"A" SQUARE
3E	5½ inches
4E	6½ inches
5E	7½ inches
6E	8½ inches
7R	10 inches
8R	11 inches

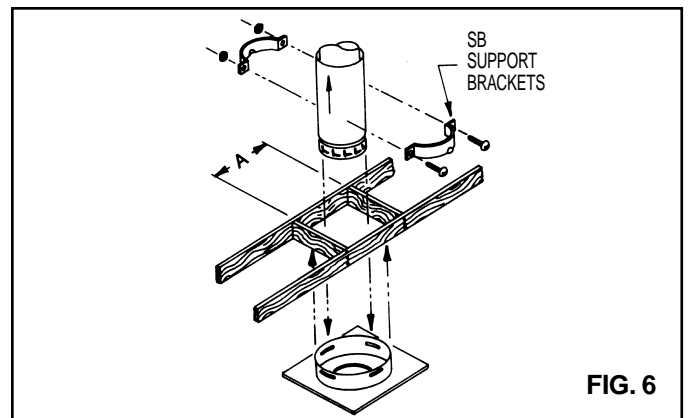
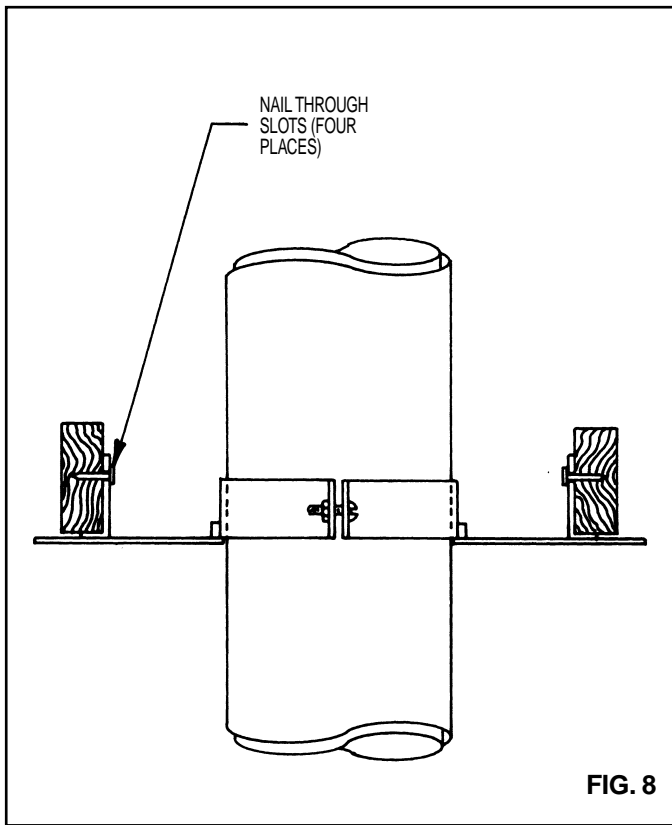
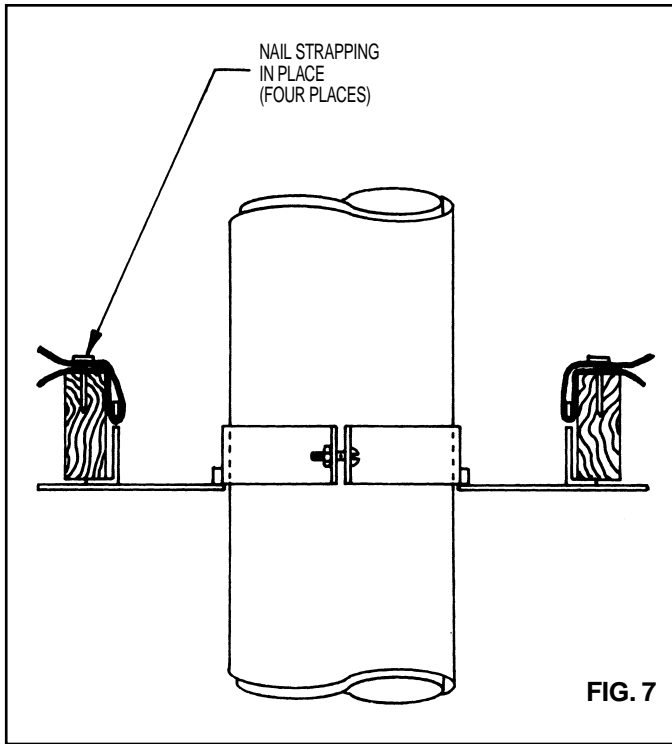

FIG. 6

3. Secure Firestop Support (FSP) as shown in Fig. 7 Install strapping (minimum 3/4 inch, 28 gauge) through all four slots in collar and nail as shown or nail at all four slots as shown in Fig. 8.



4. Pass Ameri-Vent Type B Gas Vent through opening in Firestop Support (FSP).

5. **NOTE:** If used as a support, install Support Bracket (SB) as shown in **Fig. 6**. Clamp bracket securely to pipe section using the pair of bolts and nuts provided.

For installations with multiple supports, an adjustable length section of Type B Gas Vent should be installed between each pair of locations where a Firestop Support

with Support Bracket is used. (See **Fig. 9**.) This provides relief for linear thermal expansion. The adjustable length section should be positioned directly under the Vent Pipe section which is being supported. (**NOTE:** When installed with the entire vent in a vertical position as shown in **Fig. 9**, the bottom end of the adjustable length sections should not be secured with the clamp or screws provided. This will allow movement to compensate for expansion. See section titled "Adjustable Length Sections" on **Page 7**.)

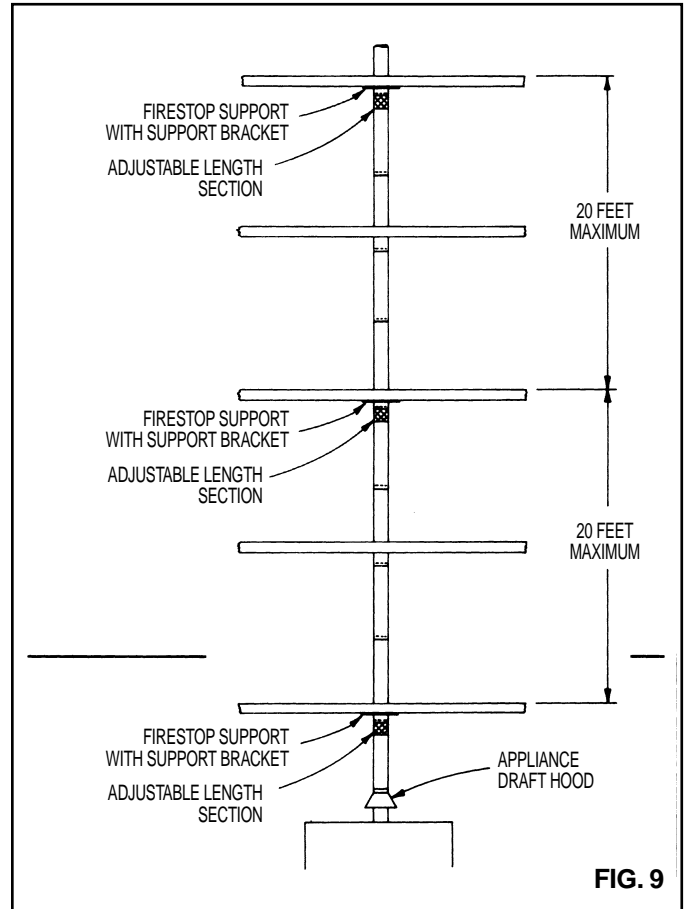

Round Support Plates

The Round Support Plate (RSP) Support is designed for use with 9 inch diameter and larger Type B Gas Vent. Each support is designed to support up to 30 feet of Vent Pipe when installed as follows:

1. It is recommended that the Vent Pipe be supported at least every other floor. The distance between supports must not, in any case exceed 30 feet.
2. The circular cutout in the Round Support Plate is designed to engage the uppermost recess in the female end of the Vent Pipe. (See **Fig. 10**.)
3. Surround the Vent Pipe with the two identical Support Plate halves. (See **Fig. 11**.) Engage the plate edges in the uppermost pipe recess as described in **Step 2**. Use two pair of bolts and nuts to hold the plate halves together. (Four predrilled tabs are provided for this purpose.)

4. Mounting holes are provided around the perimeter of the Round Support Plate. Use appropriate fasteners to secure the Support Plate halves to the opening between floors. (**NOTE:** Round Support Plates should be attached to the TOP of the opening only. See **Fig. 12.**)

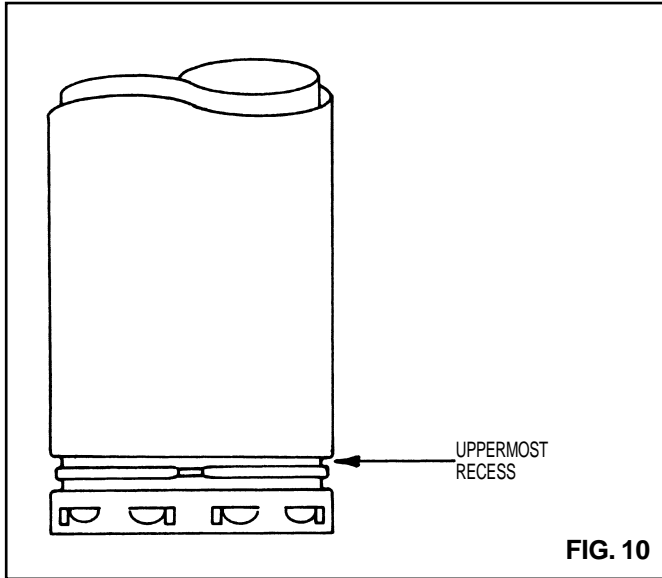

FIG. 10

5. For installations with multiple supports, an Adjustable Length Section of Type B Gas Vent should be installed between each pair of locations where a support is used. (See **Fig 12.**) This allows the location of the pipe recess to be in the proper position at each opening where a support is to be used. The Adjustable Length Section also provides relief for linear thermal expansion. The Adjustable Length Section should be positioned directly under the Vent Pipe Section which is being supported. **NOTE:** When installed with the entire vent in a vertical position as shown in **Fig. 12**, the clamps on Adjustable Length Section should be left loose to allow for expansion. (See section titled "Adjustable Length Sections" on **Page 7.**)

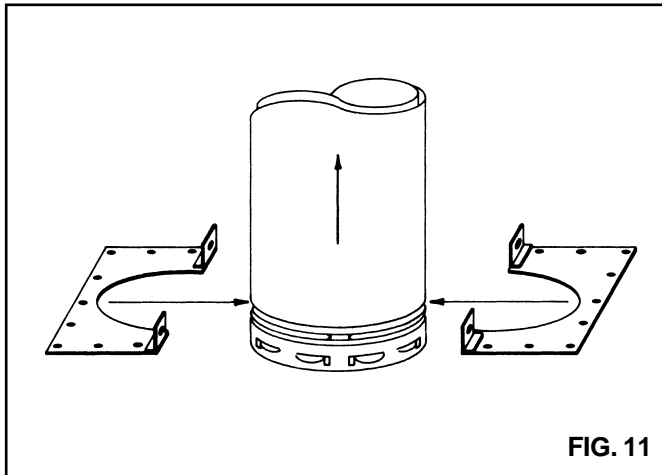

FIG. 11

Vent Pipe Hanger and Support Bracket Assembly

The Vent Pipe Hanger (VPH) (sizes 3 inch through 7 inch) and the Support Bracket Assembly (SBA) for 8 inch through 12 inch Type B Gas Vent are used to provide lateral and some vertical support for sections of Vent as well as to provide for the correct clearance to combustible materials. They also provide support and resupport for offsets and horizontal runs.

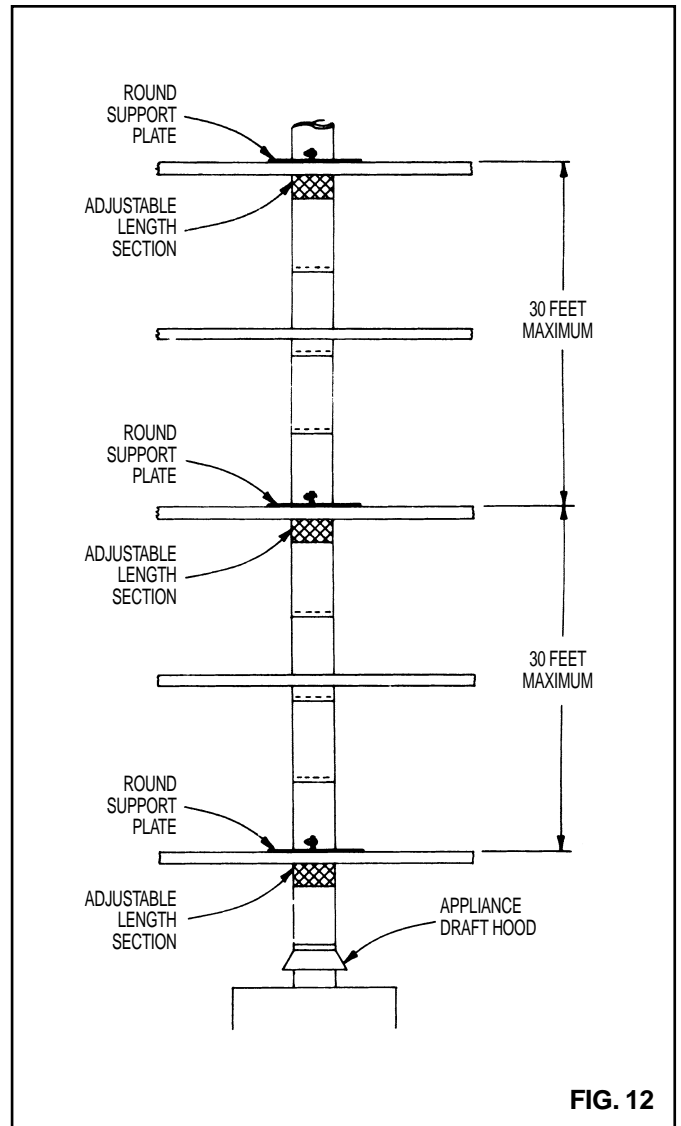

FIG. 12

Adjustable Length Sections

Adjustable Length Sections (12A and 18A) of Type B Gas Vent are available to allow for installation where fixed-length sections do not produce the desired dimensions. Sizes 3 inch through 8 inch use a single sheet metal screw which should be screwed into the mating section of Type B Gas Vent. Oval, 9 inch diameter and larger Adjustable Lengths use a clamping method consisting of a screw and tabs to draw the outer wall tightly around the mating section of Type B Gas Vent.

Adjustable Length Sections may also be used to compensate for linear thermal expansion between two fixed points in the vent system. Examples of this are shown in **Figures 9 and 12**. In these examples the fastening/clamping devices are not used. This allows for expansion between two fixed supports or between a fixed support and the appliance. Note that the fastening/ clamping means should be left loose only if the Vent and the Adjustable Length Sections are installed vertically. If the Adjustable Length Sections are used in a position other than vertical, such as between offsets, the fastening/ clamping means should be used.

Finally, when joining an Adjustable Length Section to another section of Type B Gas Vent, make sure that there is a minimum overlap of two inches.

Firestopping

All Type B Gas Vents passing through floors, ceilings or within vertical stud walls must be firestopped at floors or ceilings. The Firestop must effectively close the opening between the outer wall of the Vent Pipe and the hole cut in the structure. In attics, the Firestop should be placed on top of the framed ceiling opening to prevent insulation and debris from coming into contact with the Vent Pipe. At all other locations the Firestop should be at the bottom of the framed opening.

NOTE: The Firestop Support Plate Assembly (FSP), The Support Plate, or Vent Collar functions as a Firestop at the location where it is installed.

Wall Thimble

The Wall Thimble (WT) is available to use where a Type B Gas Vent passes through a vertical wall. The Wall Thimble will provide for the proper clearance to combustible material as the vent passes through the wall, and will also act as a firestop for the vent.

Universal Adaptors

The Universal Adaptor (EUA-M and EUA-F) is available in sizes 3 inch through 6 inch in both male and female versions. The Universal Adaptor may be used to connect Ameri-Vent round Type B Gas Vent to other manufacturers listed Type B Gas Vent as shown in **Table 2**.

1. The Universal Adaptor is installed as shown in **Fig. 13** by sliding the Adaptor over the outside wall of the other listed Type B Gas Vent. For the Male Adaptor the inner wall goes inside the other Gas Vent, while the inner wall for the Female Adaptor goes around the outside of the bottom end of the inner wall of the other Gas Vent.

Table 2

1. General Products - Air Jet
2. Hart & Cooley - Metlvent
3. Selkirk Metalbestos - Household Mfg., Eljer
4. Metal Fab
5. Mitchell Metal Products - Mitch Vent
6. Simpson Dura Vent
7. White Metal Products - Twin Stacks
8. GSW - Jakes - Evans

2. When the Universal Adaptor is in place, tighten the fastener securely.

3. The Universal Adaptor is not intended to act as a structural member and the Vent installation should be resupported.

Increasesers

An Increaser (IX) is used to make a transition from a smaller vent diameter to a larger vent diameter. The Increaser is available in steps up to a maximum of four (4) sizes larger. For example - a 4 inch diameter vent can be increased with a single Increaser from 4 inch to 8 inch or 5 inch to 9 inch.

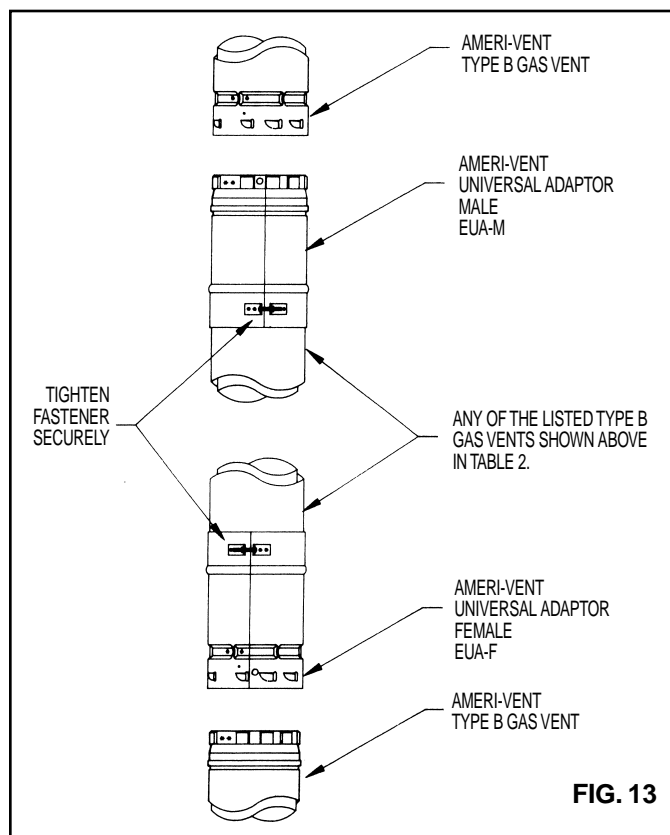
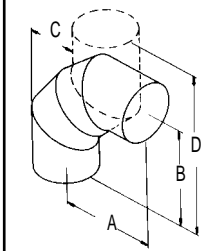

FIG. 13

Tees and Wyes

Model E and R Tees (T) and Wyes (Y) are designed for breaching or as connectors for vertical, sloped, or horizontal systems. They can also be used to provide access for inspection or drain fittings. Tees and Wyes must be isolated from expansion forces by supporting as needed and with Adjustable Length Sections. Any unused open end of the Tee or Wye should be closed off with a Tee Cap. (TC)

Table 3



CODE NO.	SIZE	A	B	C	D
3EAL	3"	5"	5 1/4"	1 1/2"	8"
4EAL	4"	5"	5 1/2"	1 3/4"	8 3/4"
5EAL	5"	5 1/2"	6"	2 1/4"	9 1/4"
6EAL	6"	6 1/2"	7"	2 1/2"	10 1/4"
7RAL	7"	7 3/4"	8"	3"	12 1/4"
8RAL	8"	8 3/4"	9"	3 1/4"	13"

Elbows and Offsets

Ameri-Vent Type B Gas Vent Model E - sizes 3 inch through 6 inch, and Model R in sizes 7 and 8 inch, is available in both a 45° and 90° fully adjustable offset. The 9 inch through 14 inch Model R is only available in a 45° adjustable elbow. The 16 inch and larger is available in 45° non-adjustable elbow. See Tables No. 3 and No. 4 for relative dimensions of offsets and combinations of offsets. Whenever Model E or R Gas Vent Pipe is changed from a vertical direction, the Vent system must be resupported before and after the change in direction. The support should provide rigid stability, both vertical and horizontally - see Fig 14. Check with your local Building Officials to make sure any alternative support method is acceptable.

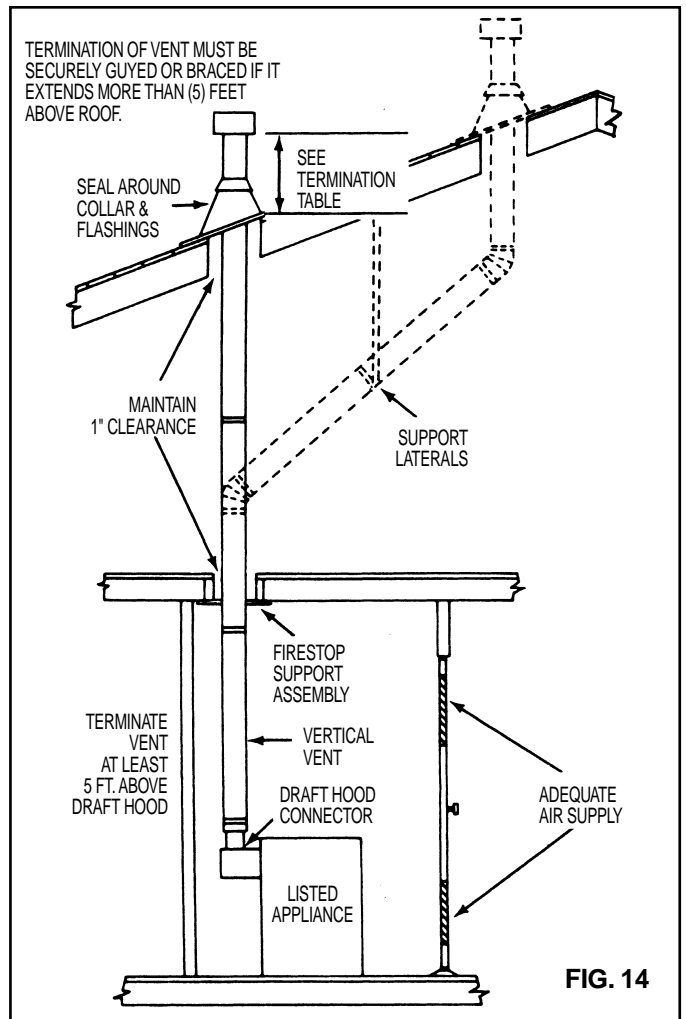
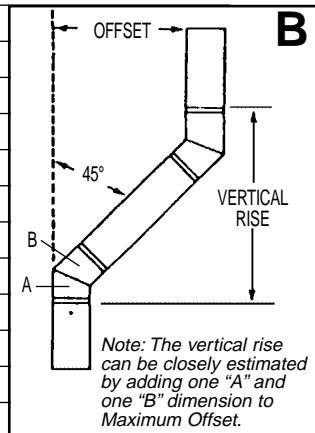

FIG. 14

Table 4

MAXIMUM OFFSET IN INCHES

Vent Size	With Two 45° Elbows ONLY			WITH 2 45° ELBOWS AND:						
	A	B	ONLY	One 6" Length	One 12" Length	One 18" Length	One 24" Length	One 3' Length	One 4' Length	One 5' Length
3	3	2 3/4	3 1/4	6 3/4	11	15 1/4	19 1/2	28	36 1/2	45
4	3 7/8	3 1/16	3 1/4	7	11 1/4	15 1/2	19 3/4	28 1/4	36 3/4	45 1/4
5	3 1/4	3 1/4	4 1/4	7 3/4	12	16 1/4	20 1/2	29	37 1/2	46
6	4	3 13/16	4 1/2	8	12 1/4	16 1/2	20 3/4	29 1/4	37 3/4	46 1/4
7	4 5/16	4 1/4	5	8 1/2	12 3/4	17	21 1/4	29 3/4	38 1/4	46 3/4
8	4 3/4	4 9/16	5 1/2	9	13 1/4	17 1/2	21 3/4	30 1/4	—	47 1/2
9	5	5	6	—	13 3/4	18	22 1/4	30 3/4	—	—
10	5 7/8	5 3/8	7 1/4	—	15	19 1/4	23 1/2	32	—	—
12	6	5 3/8	7 1/4	—	15	19 1/4	23 1/2	32	—	—
14	6 5/8	6 1/2	8 1/2	—	16 1/4	20 1/2	24 3/4	33 1/4	—	—
16	7	7	9 1/4	—	17	21 1/4	25 1/2	34	—	—
18	7 9/16	7 1/2	10	—	17 3/4	22	26 1/4	34 3/4	—	—
20	8 1/2	8 5/8	10 1/4	—	18	22 1/4	26 1/2	35	—	—
22	8	7 5/8	10 1/4	—	18	22 1/4	26 1/2	35	—	—
24	8 5/8	8 5/16	11 1/4	—	19	23 1/4	27 1/2	36	—	—
26	9	9	12	—	19 3/4	24	28 1/4	36 3/4	—	—
28	9 1/2	9 1/2	12 3/4	—	20 1/2	24 3/4	29	37 1/2	—	—
30	10	10	13 1/2	—	20 1/4	25 1/2	29 3/4	38 1/4	—	—



Section 2

Model 'O' Oval Basic Vent Structure

Ameri-Vent (Model O) Oval Gas Vent is available in sizes 4, 5, and 6 inch. The individual sizes reflect the flow rate capacities equivalent to 4 inch, 5 inch, and 6 inch Round Type B Gas Vent. The joint of the Model O Type B Oval Gas Vent takes up one inch when assembled. The Model O Gas Vent is UL listed for the following applications and

DESCRIPTION	TYPE	MINIMUM CLEARANCE
Oval Ameri-Vent (Sizes 4", 5", and 6")	B	1"
4" & 5" Oval Ameri-Vent (When installed in 2x4 stud wall with other than recessed heater)	B2x4	Clearances as determined by use of 4OFS or 5OFS Firestop Spacers at each ceiling level
4" Oval Ameri-Vent (When installed in 2x4 stud wall with recessed heater)	B-W	Clearances as determined by use of 4OHD hold down plate, 4OPS ceiling plate spacers and 4OFS firestop spacers

clearances to combustibles as shown in **Table 5**.

Type B Oval Gas Vent

Type B Oval Gas Vent is available in sizes 4, 5, and 6 inch, and requires a 1 inch clearance to combustibles. This includes all Vent Sections, Elbows, Tees, and Adaptors. When used as Type B Gas Vent, Model O must follow all of the same requirements as round Type B Gas Vent, such as the necessity of using firestops at each floor level. See **Section No. 1**

Type B 2 x 4 Gas Vent - 4" or 5" Oval

Four and five inch Ameri-Vent (Model O) Gas Vent may be installed within a standard 2x4 stud wall if **all** the following conditions are met:

1. Arrows on Ameri-Vent parts should always point up.
2. Stud bay must be a 16 inch on center stud bay.
3. 2x4 studs must be a minimum of 3.5 inches deep
4. There must be nothing else in the stud bay other than the Vent Section. **NOTE: this includes any type of insulation.**
5. The Firestop Spacer (FS) must be installed at each floor level - see **Fig. 15**.

NOTE: Only the straight Vent Pipe Sections with or without the Oval Tee may be used inside the stud bay with reduced clearances to combustibles - see Fig. 15.

Installation of Type B 2 x 4 Gas Vent

1. Cut out the ceiling plate in the space where the Vent is to be installed.
2. Nail a 2x4 support (A) at the desired height between the studs - see **Fig. 15**.
3. Attach the Tee Support (B), the Tee (C) with the Oval Tee Cap, and the Vent Pipe (D) as shown on **Fig. 15**.
4. At each floor level above the Tee install the Firestop Spacer (E) as shown in **Fig. 15**.

NOTE: Provide at least 1 inch clearance around the Tee branch where it passes through combustible wall construction.

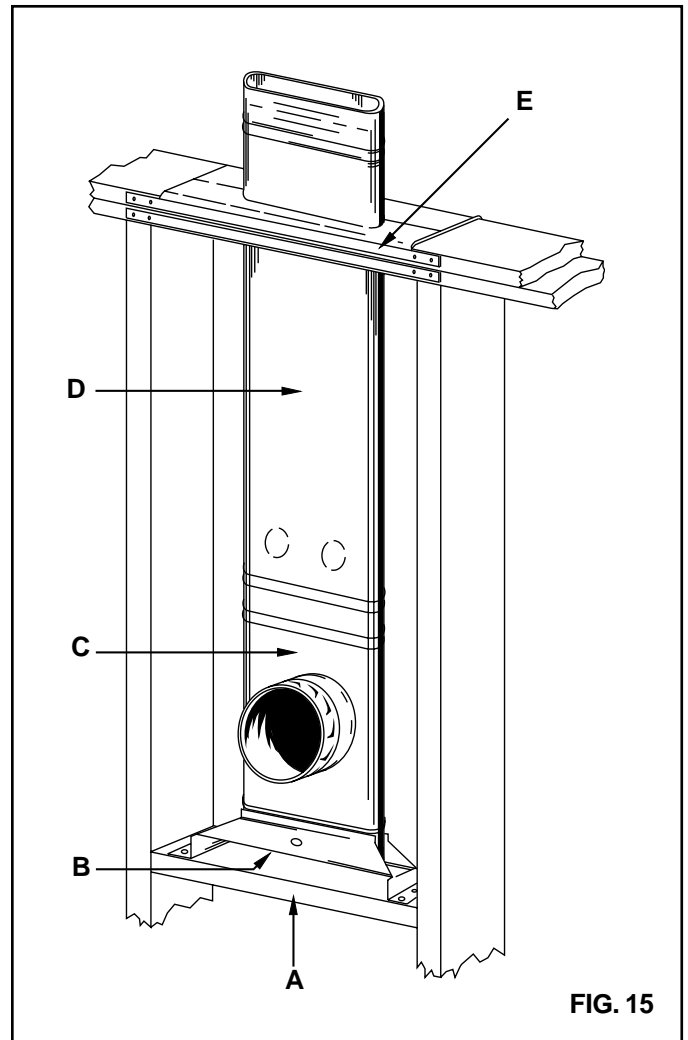

Type B-W Gas Vent - 4" Oval

Ameri-Vent (Model O) Gas Vent may be installed within a standard 2x4 stud wall if all the following conditions are met:

1. Arrows on Ameri-Vent parts should always point up.
2. Stud bay must be a 16 inch on center stud bay.
3. 2x4 studs must be a minimum of 3.5 inches deep.
4. There must be nothing else in the stud bay other than the Vent and furnace. **Note: this includes any type of insulation.**
5. The installation must contain an Oval Hold Down Plate (4OHD) at the base, Oval Plate Spacers (4OPS) at the first ceiling level, and Firestop Spacers (4OPS) at any additional floor levels. See **Fig. 16 and 17**.

Installation of Type B-W Gas Vent

1. Cut out the ceiling plate at the floor level above the heater flush with studs in space where Vent is to be installed.
2. Nail one Ameri-Vent Plate Spacer (40PS), (A), across cut out area in ceiling plate - see **Fig. 16**.
3. Snap Hold Down Plate (4OHD), (B), onto bottom end of Ameri-Vent pipe as shown in **Fig. 16**. Install Vent Section in position. Use two No. 8 binder head sheet metal screws to attach Hold Down Plate firmly to Furnace header plate through pre-punched holes.
4. Nail second Ameri-Vent Plate Spacer across cutout ceiling plate as shown in **Fig. 16**.
5. If the Vent is to continue additional stories within a 2x4 stud space, install Firestop Spacers at the second and subsequent ceiling levels as shown in **Fig. 17**.
6. After passing through the last Firestop Spacer, the Vent may be finished with either round or oval Ameri-Vent fittings, flashings and Ameri-Cap. (Round pipe, fittings, flashings and vent caps cost less than corresponding oval parts.)

Attic Insulation Shield

In some areas the building code requires the use of an attic insulation shield (AVS) on single story Type B-W installations.

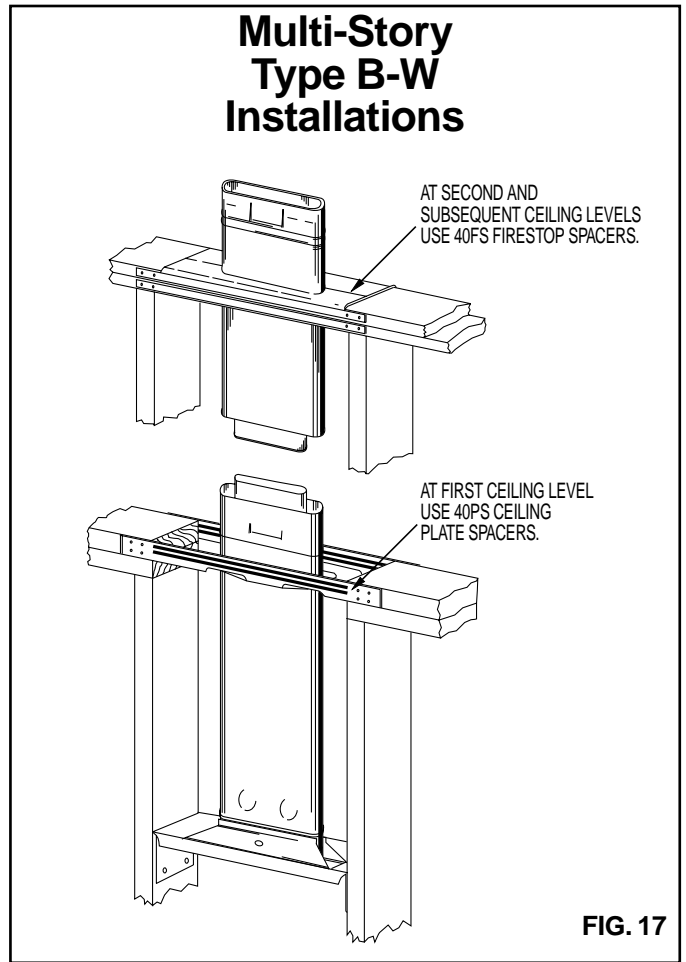
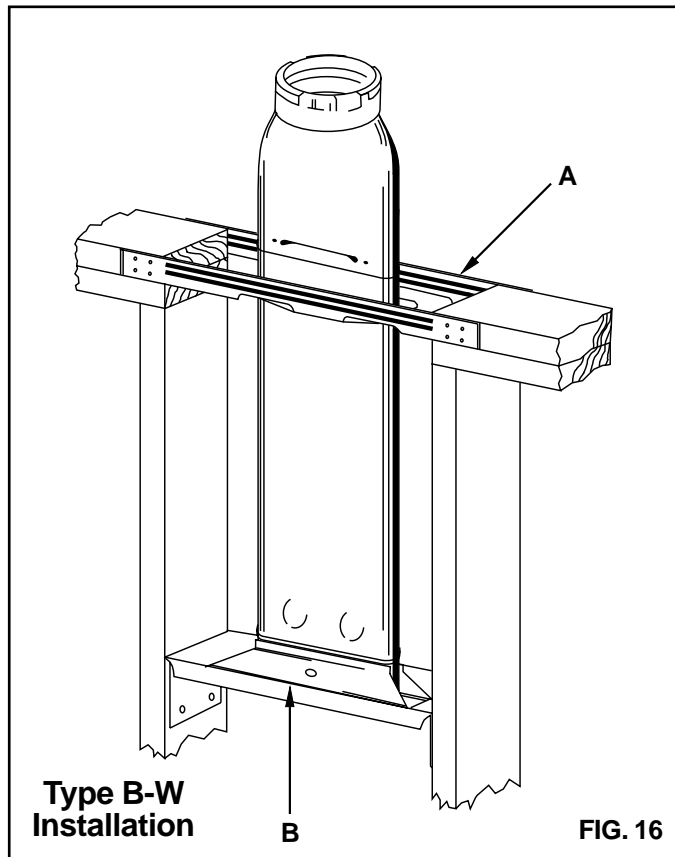

Termination of Vent Structure

The Ameri-Vent Gas Vent is available for most Models and sizes in two styles of Termination Tops, Ameri-Cap and Universal Cap. The Ameri-Cap is a lock neck design with the same lock as the female end of the Vent sections. The Universal Cap is designed to fit inside the inner wall of the vent sections.

American Metal Products 12" and smaller Gas Venting Systems using either the Ameri-Cap or the Universal Cap, may terminate in accordance with **Table 6** and **Figs. 18 & 20**.

Roof Pitch		Minimum Height
Flat to	7/12	1.0 feet
over	7/12 to 8/12	1.5 feet
over	8/12 to 9/12	2.0 feet
over	9/12 to 10/12	2.5 feet
over	10/12 to 11/12	3.25 feet
over	11/12 to 12/12	4.0 feet
over	12/12 to 14/12	5.0 feet
over	16/12 to 18/12	6.0 feet
over	18/12 to 20/12	7.0 feet
over	20/12 to 21/12	8.0 feet

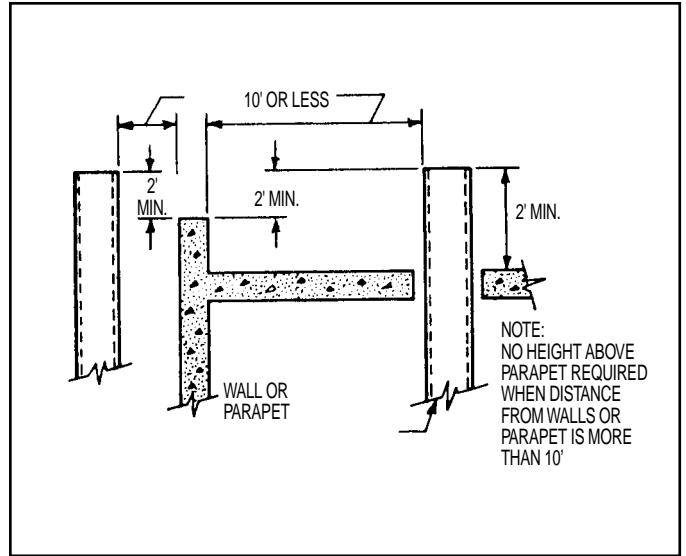
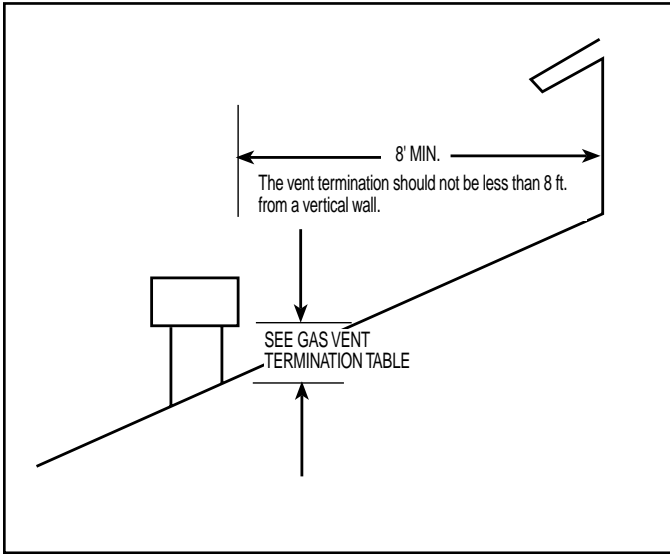

Ameri-Caps larger than 12" must be located at least 2 feet above the highest point where they pass through a roof and at least 2 feet higher than any portion of a building within a horizontal distance of 10 feet.

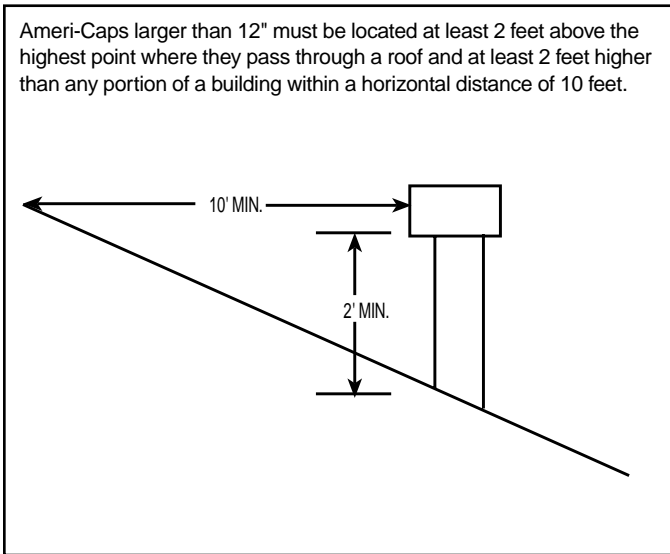

1. To ensure a waterproof roof structure, use the appropriately sized flashing and storm collar where the vent penetrates the roof. Place the Storm Collar over the vent until it is level. Apply a thick horizontal ring of non-hardening, high temperature mastic around the vent at the top of the Storm Collar.

2. Vents in excess of 5 feet above the roof should be securely guyed to prevent unnecessary movement. Attach guying to the vent. Never attach guying to the cap.

3. To prolong life and appearance of galvanized steel parts located outside, use proper painting procedure:

- Remove oil and dirt with a solvent
- Paint with primer specifically recommended for adhesion to galvanized steel
- Apply finish coat

Checking Vent Operation

After adjusting appliance and lighting main burner, allow several minutes for warm-up, to begin venting action. Hold a lighted match along the rim of the draft hood relief opening of the appliance. Proper venting will draw the flame up or into the draft hood. Improper venting, indicated by escaping or spilling of burned gas, will cause the match to flicker or go out. When consulting Standard NFPA 54, follow procedures for conducting safety inspections of existing appliances and placing equipment in operation, paying particular attention to the section titled - **Checking the Draft.**



IMPORTANT!

- 1. Connect this GAS VENT *only* to gas burning appliances, as indicated in the Installation Instructions. *Do not* connect to incinerators, or to liquid or solid fuel burning appliances.**
- 2. This VENT SYSTEM must be inspected by a *qualified professional* prior to *each* heating season. This inspection should include the removal of the Vent Termination Cap to confirm that there are no obstructions in the vent.**

IMPORTANT NOTICE TO INSTALLER !!

POST THIS NOTICE NEAR THE POINT
WHERE THE CONNECTION IS MADE TO THE
GAS VENT !



IMPORTANT!

1. Connect this GAS VENT *only* to gas burning appliances, as indicated in the Installation Instructions. *Do not* connect to incinerators, or to liquid or solid fuel burning appliances.
2. This VENT SYSTEM must be inspected by a *qualified professional* prior to *each* heating season. This inspection should include the removal of the Vent Termination Cap to confirm that there are no obstructions in the vent.



IMPORTANT!

1. Connect this GAS VENT *only* to gas burning appliances, as indicated in the Installation Instructions. *Do not* connect to incinerators, or to liquid or solid fuel burning appliances.
2. This VENT SYSTEM must be inspected by a *qualified professional* prior to *each* heating season. This inspection should include the removal of the Vent Termination Cap to confirm that there are no obstructions in the vent.

Locking and Unlocking Instructions

Model E and R

TO LOCK JOINT

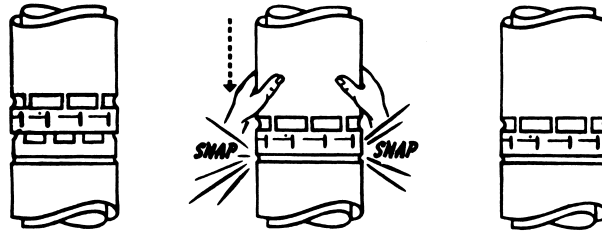

1. Line up pipe ends. (Embossed arrows must point up or away from the appliance.)
2. Press together until couplers SNAP-LOCK.
3. Pipes are now firmly connected.

TO UNLOCK JOINT

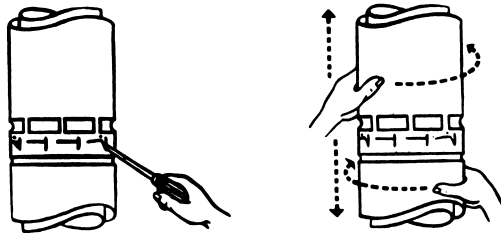

1. On sizes up to 7", pry out the 3 teeth marked with dots. For larger sizes, pry out all teeth.
2. Rotate joint slightly while pulling gently apart.

Model O

TO LOCK JOINT

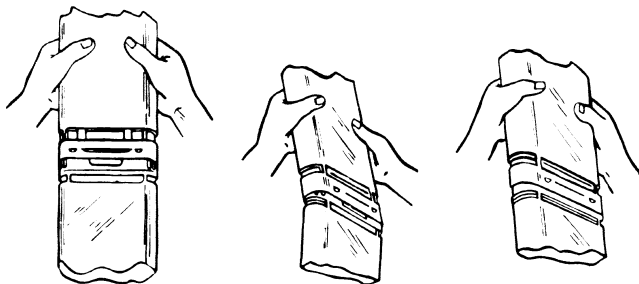

1. Place female coupler over preceding male coupler.
2. Press other side of pipe down until joint seats.
3. Press other side of pipe down until joint SNAP-LOCKS.

TO UNLOCK JOINT

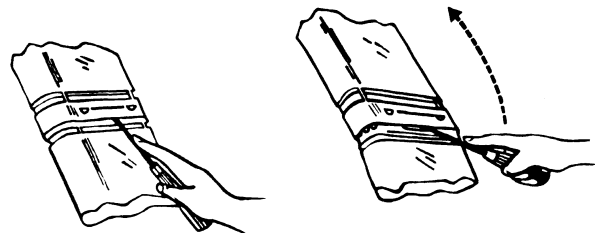

1. Insert screwdriver one inch into joint as shown.
2. Press firmly inward with blade of screwdriver and pry upwards **VERY SLOWLY AND GENTLY**. Joint will slowly separate without damage.

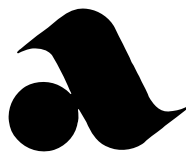

American Metal Products

8601 Hacks Cross Road Olive Branch, Mississippi 38654 • (800) 423-4270 • Fax (800) 626-3825
Technical Service Questions (800) 669-3190