



A subsidiary of
INTERNATIONAL PAPER

panel sidings

X-90[®] Smooth Primed
Ruf-X[®]
Woodsman[®]
CypresSide[®]
Stuccato[®]

202

Application Instructions

CABO-NER-224*

IMPORTANT: Read and understand all Application Instructions before installing the material.

The statements expressed in this technical bulletin are the recommendations for the application of the Masonite[®] products as outlined and illustrated under normal conditions of installation. Masonite is a manufacturer of building materials. It does not practice architecture or engineering. The recommendations provided in this bulletin represent our best judgement based on our experience to date with normal applications. These instructions supplement standard building practices and building code requirements; they are not to be deemed exclusive or exclusionary of these practices and requirements. Unless prior approval is obtained in writing from the Product Performance Department of Masonite Corporation, 1955 Powis Road, West Chicago, IL 60185, any deviation from these recommended procedures shall be at the sole risk of the installers.

These application instructions are the minimum requirements for the storage, application, and finishing of Masonite Siding products manufactured by Masonite. Where building code requirements or standards are more restrictive, the applicable regulations must be followed. Consult your local Masonite Representative or the Masonite Product Performance Department for conditions not covered by this bulletin. All drawings are shown for illustration purposes only and are not to scale. Adequate design and bracing of the walls, as well as compliance with these application instructions, are the responsibility of the architect, builder, applicator and painter.

This siding is manufactured to meet the requirements of Product Standard ANSI/AHA A135.6-1990.

*Covers Basic Building Code, Uniform Building Code and Standard Building Code.

For Manufactured Housing Application Recommendations, contact your Masonite Representative.

Wood dust generated by sawing, sanding, or other machining of board can act as a mechanical irritant affecting the eyes, upper respiratory tract and skin. Refer to the MSDS. For additional information, contact: Masonite Corporation, 1 South Wacker Drive, Chicago, IL 60606.

MASONITE SIDING MUST BE INSTALLED IN ACCORDANCE WITH THE FOLLOWING APPLICATION INSTRUCTIONS TO FULFILL WARRANTY REQUIREMENTS.

GENERAL INFORMATION

STORAGE:

1. Warehouse siding in an unheated, covered area, protected from the elements.
2. At the job site, keep siding off the ground. Store straight on properly aligned stringers, and cover the top and sides with a waterproof covering.

CUTTING:

Use a fine-tooth hand saw or power saw with a combination blade. The cutting action should be toward or into the face of the siding, i.e., face up with hand saws, face down with portable circular saws, saber saws, etc. Carbide tipped cutters are recommended for longer tool life.

WALL CONSTRUCTION:

1. It is important to provide a straight, flat wall surface for the installation of siding. Irregularities in framing and/or sheathing can mirror through the finished siding application. Such wall irregularities can be minimized with the use of seasoned framing lumber and the installation of APA Performance Rated sheathing panels.
2. Unseasoned lumber used for rim joist framing will shrink as it dries and, in the process, can distort siding attached to

it. To minimize such distortion, the moisture content of the framing lumber should not exceed 19% at the time of siding application.

3. Masonite siding products are designed for application over sheathed or unsheathed walls with studs spaced no greater than 16" o.c. This includes all framing members including floor trusses, truss joists, and gable ends.

BUILDING PAPER:

Although it is not required by Masonite, it is good building practice to install a non-vapor barrier type weather resistant barrier, accepted by the applicable building code, under the siding when the siding is applied directly to studs or over lumber sheathing. If a barrier is required by the building code, consult the building code for accepted barrier materials.

CAULK:

Caulk is **required** where siding joins materials such as wood trim, windows and doors. **Use only exterior quality caulk that remains flexible over time. Do not use hard-setting caulk.**

MOISTURE CONTROL:

1. The structure to which the siding is being applied should be well vented and dry prior to siding application. New construction should be left open to allow for venting of excess construction moisture. **DO NOT APPLY SIDING OVER WET SHEATHING.**

GENERAL INFORMATION (Cont'd)

2. Exterior walls must be constructed to prevent moisture vapor from condensing within the wall cavity. The wall design must provide protection equivalent to a continuous vapor retarder having a rating of **one (1) perm** or less, installed on the warm (living) side of the insulation. Openings made in the vapor retarder for electrical, plumbing and HVAC purposes must be sealed to control air/moisture leakage. The following materials and systems qualify as effective vapor retarders when applied in a continuous manner:

- 6 mil polyethylene.
- Vapor retarding paint applied to the inside wall surface as recommended by the paint manufacturer.
- One perm rated asphalt covered kraft, or foil facing on insulation applied with side tabs overlapped over inside stud face.
- Foil-back gypsum board.
- Other materials having a rating of one (1) perm or less may be equally effective. Consult the manufacturer of the vapor retarder for the perm rating.

3. Attics and crawl spaces must be cross ventilated to the outside with a minimum of one square foot of net free ventilation for every 150 square feet of floor area (1/150), or in accordance with local building codes, whichever is stricter.

4. A black, 6 mil, polyethylene film ground cover must be installed in all crawl space areas.

5. **Masonite Siding must not be installed in direct contact with masonry or concrete.**

GRADE CLEARANCE:

Allow at least 6" between the bottom edge of the siding and the finished grade or horizontal surfaces. Allowance must be made for landscaping. (Refer property owner to the homeowner maintenance requirements on Page 7 for landscaping restrictions.)

MASONRY/CONCRETE CONSTRUCTION

In all instances where siding is applied over masonry or concrete construction, the wall **MUST** be furred out with minimum 1½" thick framing spaced 16" o.c. A continuous 6 mil polyethylene, vapor retarding film must be placed between the framing and masonry or concrete wall. Care must be taken to prevent puncturing or tearing the film. Insulation may be installed between the framing members. **MASONITE SIDING MUST NOT COME IN DIRECT CONTACT WITH MASONRY OR CONCRETE.**

FOAM PLASTIC SHEATHING

Masonite sidings may be applied over foam plastic sheathing, if approved by applicable building codes. The following special application and construction techniques apply to the application of siding over foam sheathing thicker than 1/4".

1. Nails must be of sufficient length to insure 1-1/2" penetration into framing members. Do not overdrive siding nails, as this may cause crushing of the foam sheathing.

2. Certain types of foam sheathing may be compressed by the nailing of siding, even when nails are correctly driven. This can be minimized by predrilling all nail holes, or applying a 3" wide strip of 1/4" thick exterior grade plywood over the sheathing at every stud location. Apply the siding over the strips.

3. A weather resistant barrier may be installed between the sheathing and the siding. Consult the applicable building code for accepted materials.

(Masonite will assume no responsibility for problems related to moisture within the walls, or to crushing of foam sheathing, during or after application of siding when the application is over foam sheathing.)

FASTENING REQUIREMENTS

1. Use only corrosion resistant nails as specified in the Fastening Schedule Table. Experience has shown that hot dipped galvanized nails perform best. Electro-galvanized fasteners may exhibit premature corrosion. **(Masonite will assume no responsibility for the corrosion resistance of fasteners.)** The nail must be a minimum 1/4" diameter box head, and nail length must be sufficient to penetrate 1-1/2" into framing members. **DO NOT USE STAPLES, T-NAILS OR ANY TYPE OF COUNTER-SINKING OR TAPER-HEAD FASTENERS.**

2. Drive fasteners perpendicular to siding and framing. **DO NOT OVER-DRIVE NAIL HEADS OR DRIVE NAILS AT AN ANGLE.** In the event that a nail head is countersunk 1/8" or more, a second nail must be driven. Over-driven nail heads which are exposed to the weather must be repaired as shown.

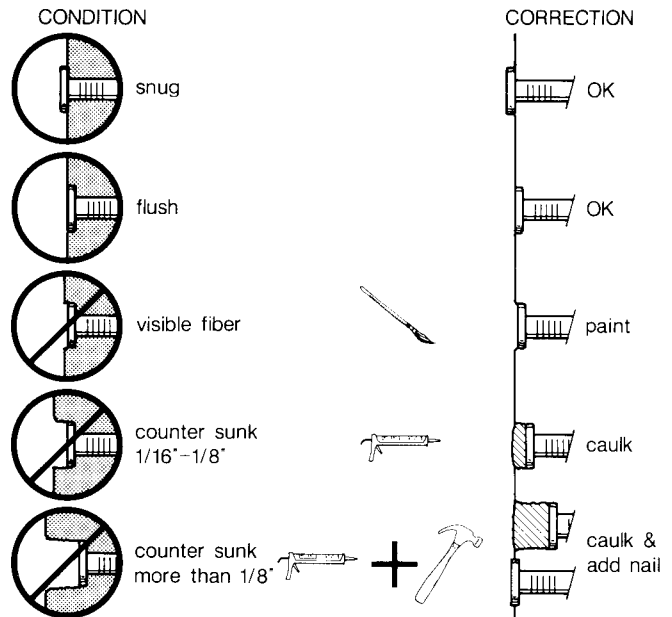

3. Power driven fastening systems are allowed for application of siding when the fasteners provide performance (nail head pull through, withdrawal strength and lateral nail resistance) equal to the nails specified in Item #1 above, and the Fastening Schedule Table. Some equipment manufacturers provide siding nailing attachments to improve fastening of all sidings. Consult your dealer for correct fasteners and equipment. Power driven fastening must conform to all fastening specifications.

FASTENING REQUIREMENTS (Cont'd)

4. The fastening of Masonite siding must comply with the following:

FASTENING SCHEDULE TABLE

Siding Type	Framing Spacing	Size Nail	Nail Spacing <u>Braced Wall</u>	Nail Spacing <u>Unbraced Wall</u>	Gap At <u>Opening</u>
Panel	16" o.c.	6d	6" o.c. all edges; 12" o.c. along intermediate support	4" o.c. all edges; 8" o.c. along intermediate supports	1/8"-3/16"

8D or 12D Nails required for unbraced walls

*Corrosion resistant box nail with the following minimum dimensions:

- a. Shank Diameter - 0.113"
Head Diameter - 1/4"
DO NOT USE TAPER-HEAD NAILS
- b. Nail must be long enough to penetrate framing at least 1-1/2".
- c. Refer to Federal Specification FF-N-105.

The recommendations shown in the Fastening Schedule Table are for applying siding direct-to-stud, and over APA Performance Rated Sheathing. Application over other sheathing will require a correspondingly longer fastener. Nail penetration must be 1-1/2" into framing member.

INSTALLATION

1. MASONITE SIDING PRODUCTS MUST NOT BE INSTALLED IN DIRECT CONTACT WITH MASONRY OR CONCRETE. Where siding overlaps or comes in contact with a masonry/concrete foundation wall, install Type 30 building paper, or 6 mil black polyethylene, or leave a minimum of 3/16" space between the siding and the concrete/masonry foundation or footing.

2. Shiplap edge panels are oversized by the width of the shiplap. Always begin the installation at an inside or outside corner. When installing the first piece of panel siding, position the overlap edge at the corner, and make certain that the opposite (underlap) edge is positioned so the nail is centered in the stud. This may require trimming the overlap edge at the starting corner for proper fit. When it is necessary to make a joint with a panel that has been field cut and the shiplap removed, butter edges with caulk and bring to light contact. All joints must fall over a framing member.

3. If wood battens are installed over the siding, vertical and horizontal edges of the trim must be caulked.

4. Nails must be located 3/8" to 1/2" from overlap edge, and must be driven straight. (See illustration). For application of panels on a braced wall, nail spacing must be 6" o.c. along all edges and 12" o.c. along intermediate supports. For application on unbraced walls where structural strength is required, use 8d or 12d galvanized box nails, 3/8" to 1/2" in from the edge, 4" o.c. along all edges, 8" o.c. along intermediate supports. (See Fastening Schedule Table.) For shear wall data see CABO-NER 224. Do not overdrive or countersink nail heads; do not drive nails at an angle.

5. Starting at a corner, joint or attached point, fasten the siding by nailing in the direction of application to the other or unattached end or side. Do not nail toward the center from both ends. Do not force or spring siding into place. Do not nail in the grooves.

6. Siding can be applied adjacent to inside and outside corners, or corner trim may be applied over siding. (See illustration)

7. Leave a 1/8"-3/16" space wherever siding adjoins trim or other materials and fill space with a non-hard-setting caulk.

8. **Caulk and flash** around door, window and other openings to insure a leak-free installation. Caulking and flashing must be designed to direct water away from the wall and never to trap water in contact with the siding or trim. Water must not be allowed to penetrate behind the siding or between the siding and horizontal trim. (See illustration — Door and Window Treatment)

9. All siding on vertical walls projecting from a roof line must be properly flashed and spaced a minimum of 2" from the plane of the roof. (See illustration)

10. Nail siding 6" o.c. above and below all window openings and above all door openings. (See illustration Detail)

11. Prime and paint all field cut edges of siding.

BAND BOARD INSTALLATION:

Installations using band boards, either horizontal or vertical, require a special application detail for all drip edges of the siding. Specifically, a horizontal Z flashing **MUST** be installed, maintaining a 15° slope on the flashing to allow water drainage away from the siding; caulk along the bottom drip edge of the siding and the flashing.

MULTI-STORY SIDING APPLICATION:

1. Over time, wood frame structures may experience shrinkage within the wall system. To compensate for this shrinkage, space stacked siding panels 1/2" apart at the horizontal joint. Install a metal Z-flashing sloping downward, in the space and caulk. (See Installation drawing detail) Waterproof in accordance with good building practices.

2. For second story installations, install the horizontal band board over the top of the siding on the level below; install the Z flashing per above, and caulk the bottom drip edge of the panels. Masonite will accept no responsibility for deteriorated panel edges when not properly installed per the above recommendations.

RESIDING:

Masonite siding can be used for residing. Refer to Supplement #207 — Residing.

Illustrated Applica

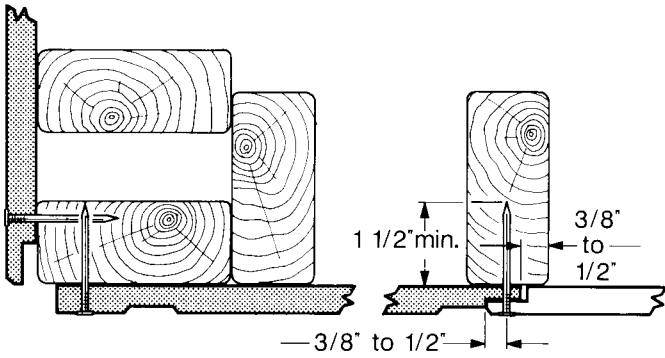

shiplap detail

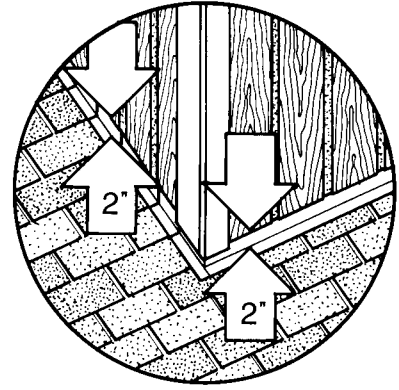

flashing detail

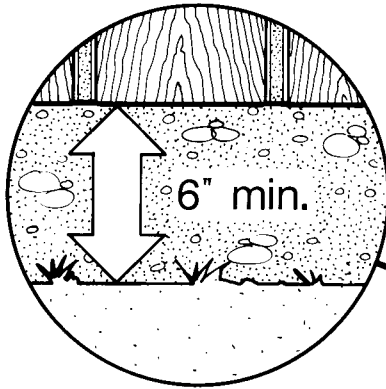

ground clearance

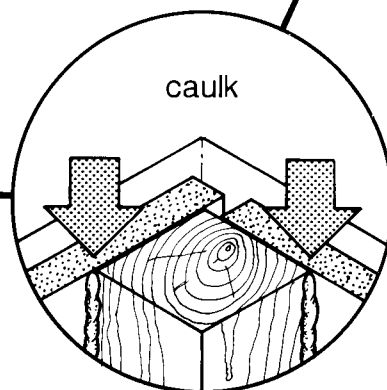
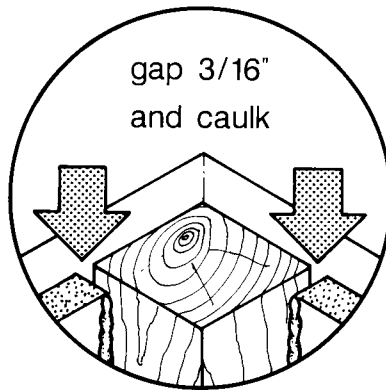
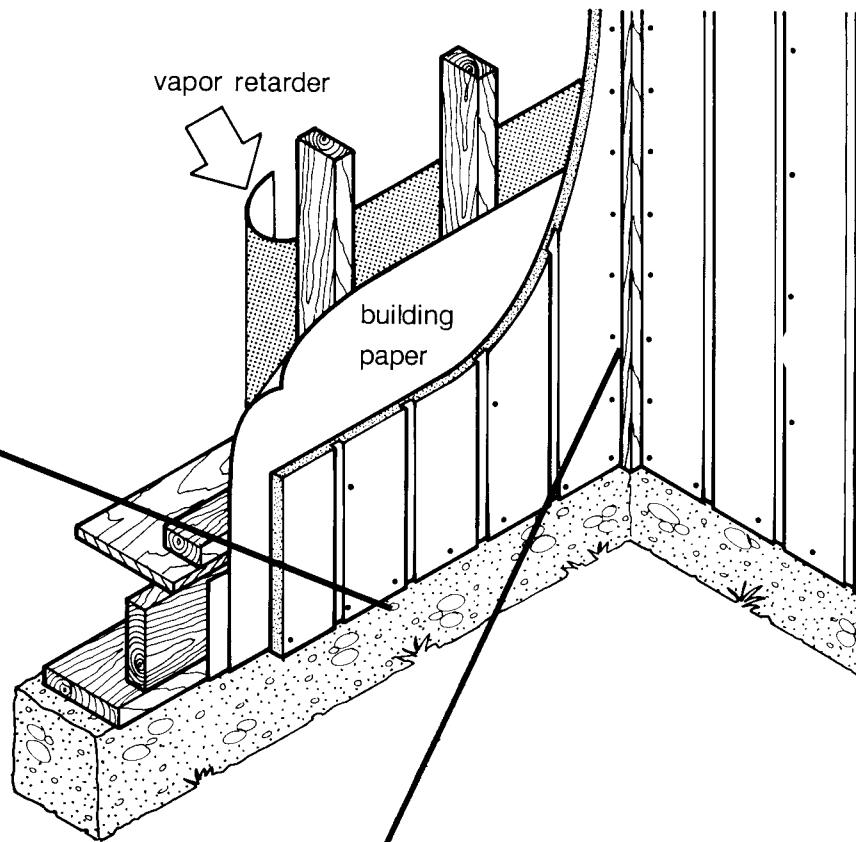

alternate inside corner details

ion Requirements

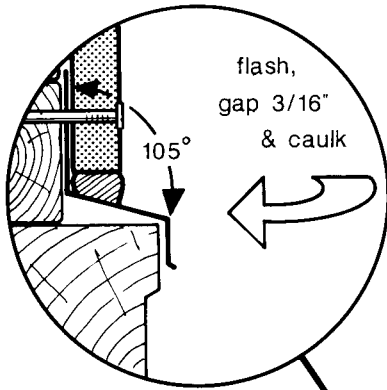

door & window
detail

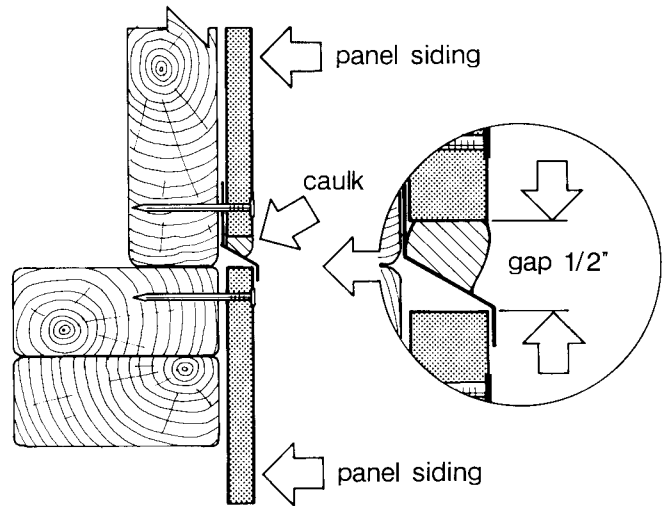

panel stacking detail

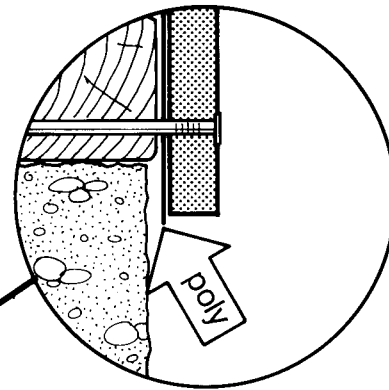
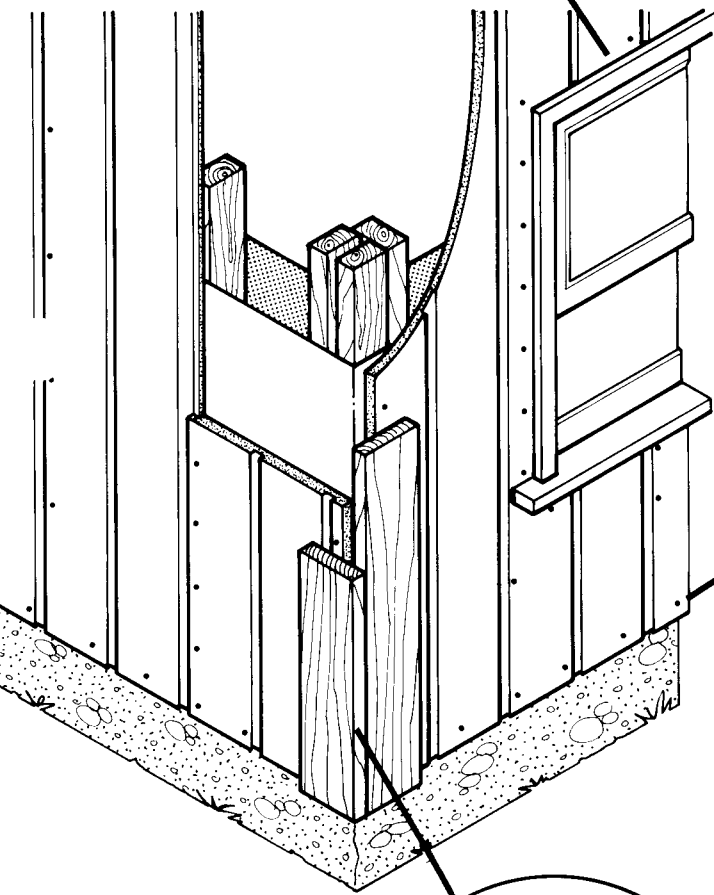

bottom course
detail

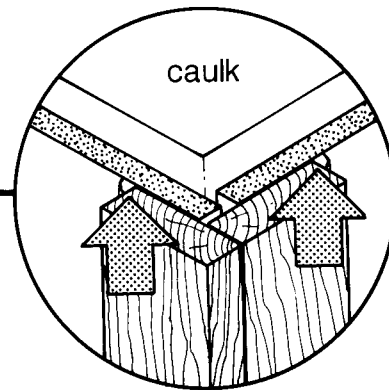
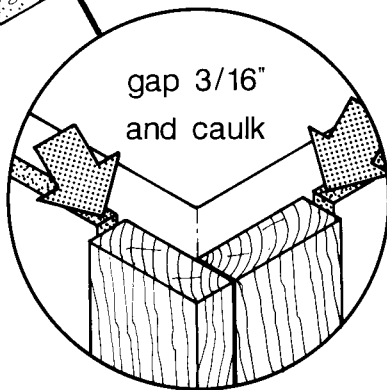

alternate outside corner details

FINISHING REQUIREMENTS

Masonite siding is manufactured from wood and must be painted with an exterior coating system in accordance with the following specifications to fulfill siding warranty requirements:

GENERAL INFORMATION:

Paint performance is dependent upon the quality and quantity of paint applied, and the conditions under which it is applied. Low quality paint, and/or thinly applied paint, tends to last for a relatively short time, resulting in discoloration, premature fading, inadequate substrate protection, and frequent repainting, sometimes as often as every one or two years. Top quality paint applied in sufficient quantity will provide best performance with minimum maintenance. **Follow the coating manufacturer's recommendations when selecting and applying a paint.**

SURFACE PREPARATION:

The siding surface must be free of dust, dirt, mildew, and other foreign materials before painting. Washing with water and a mild detergent will usually remove dust and dirt. Allow the surface to dry before painting. If mildew is present, contact a paint supply store for recommended methods of removing and controlling mildew. **The control of mildew on the surface of paint is a homeowner maintenance responsibility. Masonite will assume no responsibility for the treatment and prevention of mildew.**

PAINT SELECTION:

For best results, use satin/semi-gloss or full gloss exterior acrylic latex or a satin/semi-gloss or full gloss exterior oil-base paint. All exposed siding surfaces, including bottom edges, must be well coated. Semi-gloss or full gloss finishes tend to perform better than flat finishes. **Note: Some systems may require the application of a designated primer and topcoat combination.**

DO NOT USE THE FOLLOWING COATINGS:

Shake and shingle paints	Vinyl acrylic paint *
Flat oil paint	Vinyl acetate paint
STAINES	Vinyl acetate/co-polymer paint
	Clear coatings

***Note: Although vinyl acrylic exterior paint may be readily available, it must NOT be used on Masonite siding. Vinyl acrylic paint tends to weather more quickly than full acrylic paint, and may discolor.**

PAINT APPLICATION:

Always follow the paint manufacturer's recommendations for the application and maintenance of field-applied paints.

1. PRIME AND PAINT ALL FIELD CUT EDGES OF MASONITE SIDING.

2. ALL EXPOSED SURFACES OF SIDING INCLUDING THE BOTTOM EDGE (DRIP EDGE), MUST BE WELL COATED. Because of its location, the bottom edge is often not adequately protected with paint. Inadequate coverage of the bottom edge may result in the conditions described at the beginning of this section (Finishing Requirements) and can result in deterioration of the siding.

3. Masonite factory-primed siding must be finished with two coats of paint within 90 days after installation. If, due to unforeseen circumstances, the siding is not painted within 90 days, reprime the siding using an exterior primer that is specifically recommended for use on wood-based siding and is compatible with the topcoat to be used. Use the same primer for repair of any damage to the original factory applied primer.

4. A total field-applied dry film paint thickness of at least 2-1/2 mils is required on Masonite Siding. This requires the application of 2 or more unthinned coats of paint at the spread rate recommended by the paint manufacturer. **NOTE:** The paint manufacturer may require a primer and topcoat combination.

5. Most coatings can be applied with brush, roller, pad or spray. The brush application method tends to apply the most paint per coat; spraying tends to apply the least per coat.

6. The siding surface temperature must not be less than 50°F for 24 hours following the application of water based paint. Paint performance problems can be avoided by not applying paint in the evenings of cool spring and fall days when heavy dew can form before the surface of the paint has thoroughly dried. Allow at least 2 hours for the paint to dry before sunset. Likewise, painting in the morning should not begin until after the dew has had time to evaporate. Serious water absorption problems, and major finish failure can occur with some latex paints when applied under these conditions.

Masonite is not responsible for the performance of field applied finishes. Finish performance is dependent upon coating quality and application methods which are factors controlled by the finish manufacturer and applicator.

PREFINISHED SIDING

The surface of factory prestained and prepainted siding does not require field finishing for the life of the applicable finish warranty. However, all field cut edges which are exposed to the weather must be field primed and painted as specified

above. Any damage to the finish must be repaired with matching touch-up paint. Exercise care in touching up to minimize spreading paint to undamaged areas. The refinishing of prefinished siding within the warranty period may require special coating procedures. Contact the Masonite Product Performance Department for recommendations prior to refinishing.

HOMEOWNER MAINTENANCE

Maintenance is a homeowner responsibility and not the responsibility of Masonite. Failure to follow maintenance requirements will void the warranty.

An annual inspection of the exterior of the home will help prevent costly repairs. A checklist should include the condition of caulk, the presence of mildew, the condition of the paint, and the proper drainage of water off, and away from the home.

CAULK:

Loose and cracked caulk must be removed and replaced with a good quality exterior acrylic latex caulk or equivalent. **DO NOT USE HARD-SETTING CAULKING MATERIALS.**

PAINT:

The condition of the paint should be checked annually and maintained as noted in the following table:

<u>CONDITION OF PAINT</u>	<u>ACTION REQUIRED</u>
• Good condition, unbroken, non-chalked	• Clean to remove dirt
• Thin, but unbroken, and well-adhered to siding	• Clean and apply two topcoats
• Badly eroded, substrate showing through paint	• Clean, prime and apply two topcoats
• Cracked, flaking, exposed substrate	• Remove loose paint film, clean, prime and apply two topcoats

MILDEW:

Paint appearance can be affected by the presence of mildew. Mildew is a living organism (fungus) that grows on the surface of paint, giving the paint a darkened, dirty appearance. Painting over mildew will not control its growth. It must be removed prior to painting by using a commercial mildew wash available at many paint stores. **It is important to follow label instructions carefully and to heed all warnings when using a mildew wash.**

Once the mildew is removed, its growth MAY be controlled with paint that is certified by the manufacturer as mildew-resistant. Supplemental mildewcide purchased at paint stores can be added to paint for additional control. **The control of mildew on the surface of paint is a homeowner maintenance responsibility. Masonite IS NOT RESPONSIBLE for the treatment or prevention of mildew.**

MISCELLANEOUS:

Masonite Siding is made of wood, and like any wood product, it must be treated in the following manner:

1. Wash painted surfaces with water and mild detergent to remove accumulated dirt. The frequency of washing will depend on location conditions.
2. Locate landscape sprinklers so water will not hit siding. Keep landscape foliage at least 12" away from siding.
3. Divert drainage water from roofs away from the siding with the use of gutters or similar devices. Allowing water from the roof to run down the surface of the siding can cause discoloration and accelerated erosion of the paint.
4. Keep the bottom edge of siding at least 6" above the finished landscape grade, or horizontal surfaces such as decks and sidewalks.
5. Do not allow wood or Masonite siding to, 1) stand in water, 2) be in direct contact with concrete/masonry, or 3) be in continuous contact with wet/moist surfaces. Continuous exposure to water without an opportunity to dry will lead to deterioration of wood and wood-based materials such as Masonite siding.

MASONITE® HARDBOARD SIDING LIMITED WARRANTIES

25 YEAR LIMITED WARRANTY — SUBSTRATE

Masonite® hardboard siding substrate, when properly installed and maintained according to Masonite's published application instructions, is warranted for a period of 25 years from the date of installation: (A) to meet, as of the date of purchase, the hardboard industry standard ANSI/AHA A135.6 as published by the American National Standards Institute; and (B) against hail damage, delamination, splitting or cracking of the substrate face under normal conditions of use and exposure when caused by substrate defects. If Masonite, after inspection and verification, determines that the Siding failed under the terms of this limited warranty, the **sole and exclusive remedy** provided by Masonite will be as follows: during the first five years of the warranty period following installation, Masonite will compensate the Owner for correcting the affected siding limited to twice the original purchase price of the affected Siding. Starting with the sixth year following installation, the amount payable will be reduced by 5% each year until the end of the limited warranty period for the affected Siding.

5 YEAR LIMITED WARRANTY — PRIMECOTE®

The factory-applied primer on Masonite Siding, when properly installed, field-finished and maintained according to Masonite's published application instructions, and used and exposed under normal conditions, is warranted for a period of five years from the date of installation against blistering or peeling. The limited warranty does not extend to field-applied finish coatings. If Masonite, after inspection and verification, determines that the factory-applied primer failed under the terms of this limited warranty, the **sole and exclusive remedy** provided by Masonite will be to compensate the Owner for correcting the affected Siding limited to the original purchase price of the affected Siding.

5 YEAR LIMITED WARRANTY — FACTORY FINISH

Masonite Prefinished Harboard Siding (the Siding), when installed according to Masonite's published application instructions and when properly maintained, is warranted for a period of 5 years from the date of installation, not to require refinishing due to peeling, blistering, cracking or erosion of the factory-applied finish except for reasonable fade from normal weathering. If Masonite, after inspection and verification, determines that the factory-applied finish failed under the terms of this warranty, the **sole and exclusive remedy** provided by Masonite will be to compensate the Owner for correcting the finish problem on the affected Siding limited to a maximum of the original purchase price of the affected Siding.

GENERAL PROVISIONS AND LIMITATIONS

THE LIMITED WARRANTIES ARE SUBJECT TO THE FOLLOWING GENERAL PROVISIONS AND LIMITATIONS.

The limited warranties are effective only if there is proper storage, handling, installation and maintenance of the Siding in strict accordance with the instructions packaged with the particular Siding product and the maintenance instructions printed on the reverse side.

Claims must be made in writing to Masonite within 60 days of the discovery of a problem and authorization obtained prior to beginning any repair or replacement work. Claims can be made by writing, certified or registered mail to Masonite Corporation, 1955 Powis Road, West Chicago, IL 60185; Attention: Product Performance Department. After receiving such notice of the alleged defect, Masonite will investigate the claim. Masonite must be given a reasonable opportunity to inspect and verify the claim. Under no circumstance will the total compensation under these limited warranties exceed twice the purchase price in total.

Masonite shall have no liability for defects or damage resulting from (A) misuse or abuse, (B) improper installation, including, but not limited to, inadequate protection against all sources of moisture accumulation within the wall cavity, (C) lack of proper maintenance, such as prolonged contact with accumulated water due to failure to maintain caulking, finish coatings, or other normal weather protection, (D) performance of coatings other than those covered by the limited warranties, (E) contact with harmful chemicals, fumes, vapors or air pollutants, (F) mildew, (G) settlement, shrinkage, or distortion of the structure, or (H) other causes beyond the control of Masonite, such as acts of God, fire and casualty. Masonite shall have no liability for the cost of removing affected Siding. The warranty period for any replacement Siding will expire upon the expiration of the warranty period for the original Siding.

DISCLAIMER OF IMPLIED WARRANTIES & LIMITATION OF REMEDIES

THE LIMITED WARRANTIES STATE THE ENTIRE LIABILITY OF MASONITE WITH RESPECT TO THE PRODUCTS COVERED BY THEM. MASONITE SHALL HAVE NO LIABILITY FOR ANY INCIDENTAL OR CONSEQUENTIAL DAMAGES. NO PERSON IS AUTHORIZED TO MAKE ANY REPRESENTATION OR WARRANTY ON BEHALF OF MASONITE EXCEPT AS EXPRESSLY SET FORTH ABOVE, AND ANY SUCH STATEMENT SHALL NOT BE BINDING ON MASONITE. Some states do not allow the exclusion or limitation of incidental or consequential damages, so the above limitation or exclusion may not apply to you.

EXCEPT AS EXPRESSLY SET FORTH ABOVE, MASONITE MAKES NO WARRANTY OF ANY KIND, EXPRESS OR IMPLIED, INCLUDING, WITHOUT LIMITATION, ANY IMPLIED WARRANTY OF MERCHANTABILITY OR FITNESS FOR A PARTICULAR PURPOSE. THE FOREGOING DISCLAIMER OF IMPLIED WARRANTIES SHALL NOT BE APPLICABLE TO SALES SUBJECT TO THE MAGNUSON-MOSS WARRANTY ACT, IN WHICH CASE THE DURATION OF ANY IMPLIED WARRANTY SHALL BE THE DURATION OF THE LIMITED WARRANTY OR SUCH SHORTER DURATION AS PROVIDED UNDER APPLICABLE STATE LAW. Some states do not allow limitations on how long an implied warranty lasts, so the above limitation may not apply to you. These limited warranties give you specific legal rights, and you may also have other rights which vary from state to state.



**MASONITE
CORPORATION**

BUILDING AND INDUSTRIAL PRODUCTS
ONE SOUTH WACKER DRIVE
CHICAGO, IL 60606

Printed in the USA

© 1997 Masonite Corporation

PrimeCote and Masonite are registered trademarks of Masonite Corporation
942202 R 3/97